



RACCORDI a SETTORE PE80 PE100

segmented fittings PE80 PE100

raccords à secteurs PE80 PE100

uniones a sectores PE80 PE100

90°

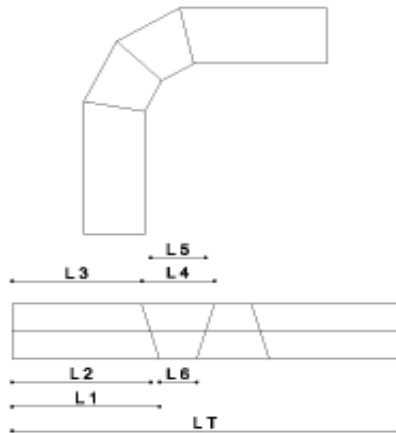

60°

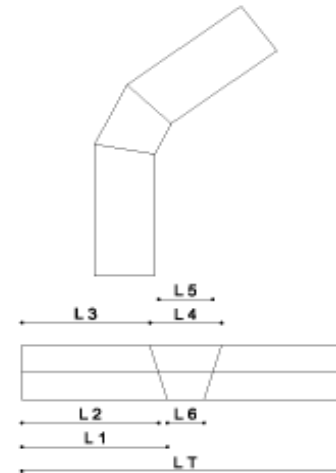

30°

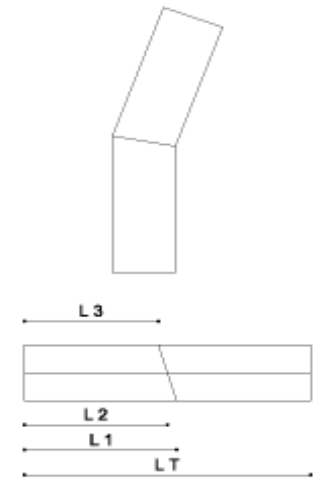

CURVA 90°

CURVA 60°

CURVA 30°

GRADO TAGLIO

SALDATURE N°

15°

3

GRADO TAGLIO

SALDATURE N°

15°

2

GRADO TAGLIO

SALDATURE N°

15°

1

D/	L T	L 1	L 2	L 3	L 4	L 5	L 6	L T	L 1	L 2	L 3	L 4	L 5	L 6	L T	L 1	L 2	L 3	D/
315	1.972	768	726	684	344	260	176	1.712	768	726	684	344	260	176	1.452	768	726	684	315
280	1.884	750	712	674	305	230	155	1.654	750	712	674	305	230	155	1.424	750	712	674	280
250	1.610	633	600	567	272	205	138	1.405	633	600	567	272	205	138	1.200	633	600	567	250
225	1.550	620	590	560	245	185	125	1.365	620	590	560	245	185	125	1.180	620	590	560	225
200	1.488	607	580	553	218	164	110	1.324	607	580	553	218	164	110	1.160	607	580	553	200
180	1.440	596	572	548	196	148	100	1.292	596	572	548	196	148	100	1.144	596	572	548	180
160	1.192	485	464	443	175	132	89	1.060	485	464	443	175	132	89	928	485	464	443	160
140	1.142	475	456	437	153	115	77	1.027	475	456	437	153	115	77	912	475	456	437	140
125	1.106	467	450	433	136	103	70	1.003	467	450	433	136	103	70	900	467	450	433	125
110	1.068	459	444	429	119	90	61	978	459	444	429	119	90	61	888	459	444	429	110
90	1.020	448	436	424	98	74	50	946	448	436	424	98	74	50	872	448	436	424	90

Misura : 1,5 X Ø

LAVORAZIONI QUADRE O RETTANGOLARI

da 0 a 250 mm

da 251 mm a 1000 mm

da 1001 mm a 2000 mm

oltre 2001 mm

± mm.

2,5

± mm.

10

± mm.

15

± mm.

20

LAVORAZIONI CIRCOLARI

dal Ø 0 al 50

dal Ø 51 al 250

dal Ø 251 al 500

oltre Ø 501

± mm.

1,5

± mm.

5

± mm.

10

± mm.

15

LAVORAZIONI AD ANGOLO

tutti i Ø

± °

2

90°

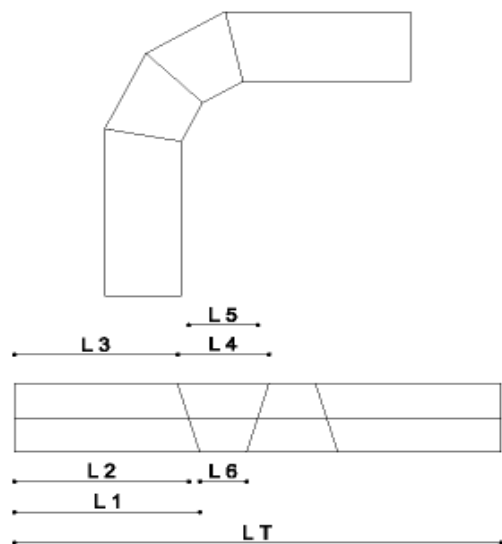

60°

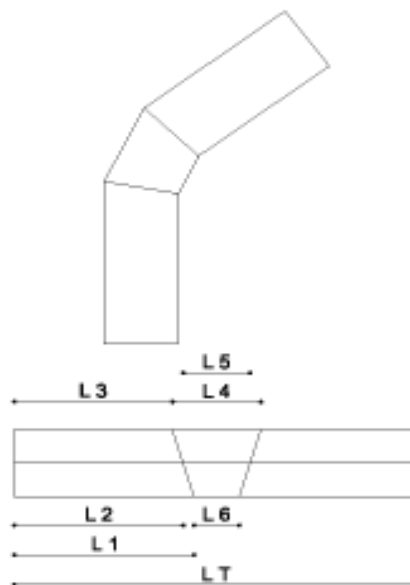

30°

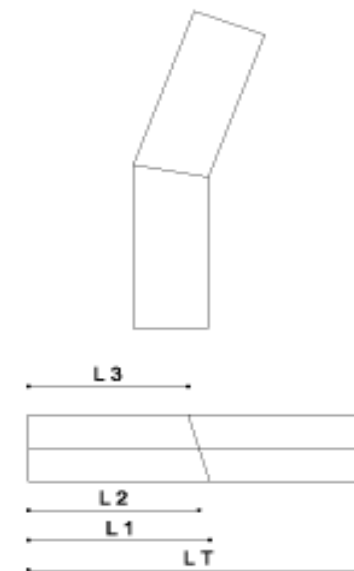

CURVA 90°

CURVA 60°

CURVA 30°

GRADO TAGLIO

15°

GRADO TAGLIO

15°

GRADO TAGLIO

15°

SALDATURE N°

3

SALDATURE N°

2

SALDATURE N°

1

D/	L T	L 1	L 2	L 3	L 4	L 5	L 6	L T	L 1	L 2	L 3	L 4	L 5	L 6	L T	L 1	L 2	L 3	D/
630	3.344	1.237	1.152	1.068	689	520	351	2.824	1.237	1.152	1.068	689	520	351	2.304	1.237	1.152	1.068	630
560	3.168	1.200	1.124	1.049	610	460	310	2.708	1.200	1.124	1.049	610	460	310	2.248	1.200	1.124	1.049	560
500	3.020	1.167	1.100	1.033	544	410	276	2.610	1.167	1.100	1.033	544	410	276	2.200	1.140	1.100	1.033	500
450	2.900	1.140	1.080	1.020	491	370	249	2.530	1.140	1.080	1.020	491	370	249	2.160	1.140	1.080	1.020	450
400	2.176	814	760	706	435	328	221	1.848	814	760	706	435	328	221	1.520	814	760	706	400
355	2.068	790	742	694	387	292	197	1.776	790	742	694	387	292	197	1.484	790	742	694	355
315	1.972	768	726	684	344	260	176	1.712	768	726	684	344	260	176	1.452	768	726	684	315

Misura : 1,5 X Ø

LAVORAZIONI QUADRE O RETTANGOLARI			LAVORAZIONI CIRCOLARI			LAVORAZIONI AD ANGOLO		
da 0 a 250 mm	± mm.	2,5	dal Ø 0 al 50	± mm.	1,5	tutti i Ø	± °	2
da 251 mm a 1000 mm	± mm.	10	dal Ø 51 al 250	± mm.	5			
da 1001 mm a 2000 mm	± mm.	15	dal Ø 251 al 500	± mm.	10			
oltre 2001 mm	± mm.	20	oltre Ø 501	± mm.	15			

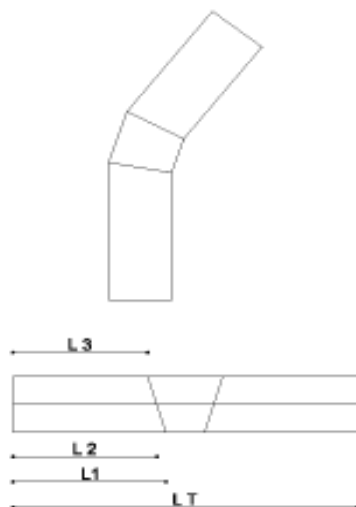
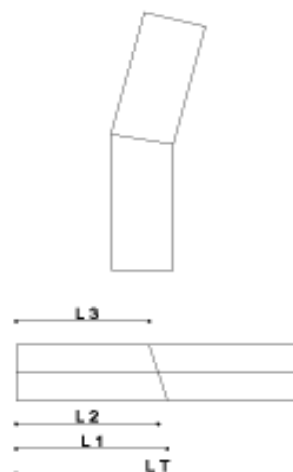
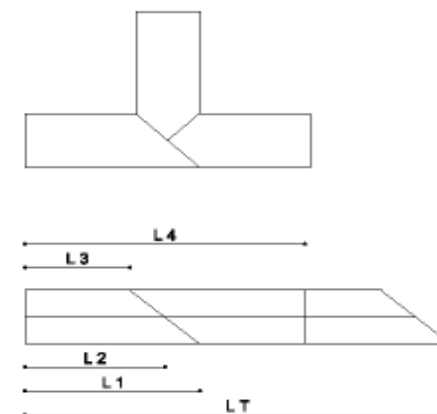
45°

15°

TEE 90°

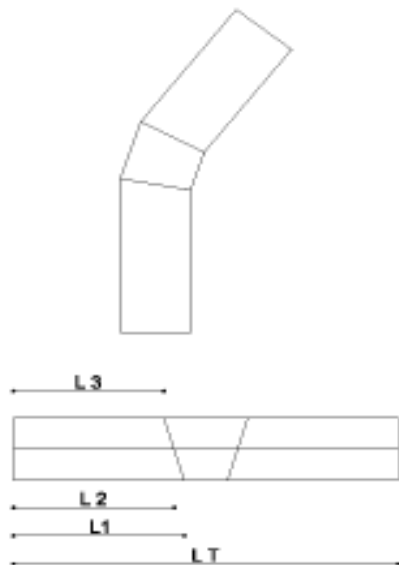
CURVA 45°								CURVA 15°				TEE 90°					
GRADO TAGLIO				11,25°				GRADO TAGLIO		7,5°		GRADO TAGLIO			45°		
SALDATURE N°				2				SALDATURE N°		1		SALDATURE N°			2		
D/	L T	L 1	L 2	L 3	L 4	L 5	L 6	L T	L 1	L 2	L 3	L T	L 1	L 2	L 3	L 4	D/
315	1.712	757	726	695	323	260	197	1.452	747	726	705						315
280	1.654	740	712	684	286	230	174	1.424	730	712	694						280
250	1.405	625	600	575	255	205	155	1.200	616	600	584	2.000	750	625	500	1.250	250
225	1.365	612	590	568	230	185	140	1.180	605	590	575	1.948	724	612	500	1.224	225
200	1.324	600	580	560	204	164	124	1.160	593	580	567	1.900	700	600	500	1200	200
180	1.292	590	572	554	184	148	112	1.144	584	572	560	1.860	680	590	500	1180	180
160	1.060	480	464	448	164	132	100	928	475	464	453	1.520	560	480	400	960	160
140	1.027	470	456	442	143	115	87	912	465	456	447	1.480	540	470	400	940	140
125	1.003	462	450	438	128	103	78	900	458	450	442	1.450	525	463	400	925	125
110	978	455	444	433	112	90	68	888	451	444	437	1.420	510	455	400	910	110
90	946	445	436	427	92	74	56	872	442	436	430	1.380	490	445	400	890	90
Misura : 1,5 X Ø								LAVORAZIONI QUADRE O RETTANGOLARI				LAVORAZIONI CIRCOLARI			LAVORAZIONI AD ANGOLO		
								da 0 a 250 mm	± mm.	2,5	dal Ø 0 al 50	1,5	tutti i Ø	± °	2		
								da 251 mm a 1000 mm	± mm.	10	dal Ø 51 al 250	5					
								da 1001 mm a 2000 mm	± mm.	15	dal Ø 251 al 500	10					
								oltre 2001 mm	± mm.	20	oltre Ø 501	15					

45°

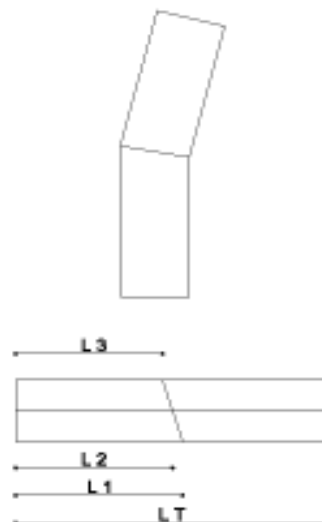

15°



TEE 90°

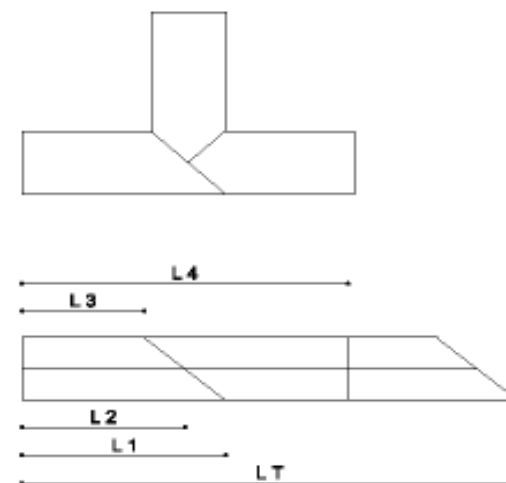

CURVA 45°								CURVA 15°				TEE 90°									
GRADO TAGLIO								11,25°				GRADO TAGLIO				7,5°		GRADO TAGLIO		45°	
SALDATURE N°								2				SALDATURE N°				1		SALDATURE N°		2	

D/	LT	L 1	L 2	L 3	L 4	L 5	L 6	LT	L 1	L 2	L 3	LT	L 1	L 2	L 3	L 4	D/
630	2.824	1.215	1.152	1.090	645	520	395	2.304	1.193	1.152	1.111						630
560	2.708	1.180	1.124	1.069	572	460	349	2.248	1.161	1.124	1.087						560
500	2.610	1.150	1.100	1.050	510	410	310	2.200	1.133	1.100	1.067	3.700	1.400	1.150	900	2.300	500
450	2.530	1.125	1.080	1.035	460	370	280	2.160	1.110	1.080	1.050	3.600	1.350	1.124	900	2.250	450
400	1.848	780	760	720	408	328	248	1.520	786	760	734	2.600	1.000	800	600	1600	400
355	1.776	777	742	707	363	292	221	1.484	765	742	719	2.510	955	778	600	1555	355
315	1.712	757	726	695	323	260	197	1.452	747	726	705	2.430	915	757	600	1515	315
												2.360	880	740	600	1480	218

<p>Misura : 1,5 X Ø</p>	LAVORAZIONI QUADRE O RETTANGOLARI			LAVORAZIONI CIRCOLARI			LAVORAZIONI AD ANGOLO		
	da 0 a 250 mm	± mm.	2,5	dal Ø 0 al 50	± mm.	1,5	tutti i Ø	± °	2
	da 251 mm a 1000 mm	± mm.	10	dal Ø 51 al 250	± mm.	5			
	da 1001 mm a 2000 mm	± mm.	15	dal Ø 251 al 500	± mm.	10			
	oltre 2001 mm	± mm.	20	oltre Ø 501	± mm.	15			

90°

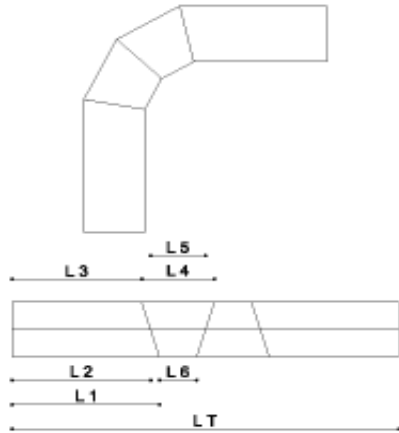

60°

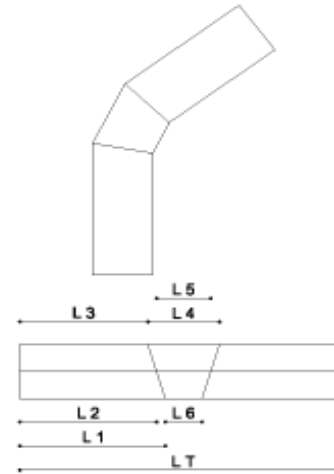

30°

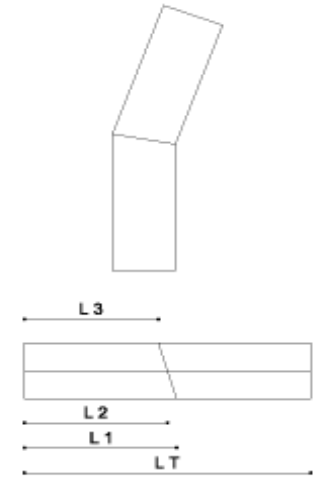

CURVA 90°

CURVA 60°

CURVA 30°

GRADO TAGLIO

SALDATURE N°

15°

3

GRADO TAGLIO

SALDATURE N°

15°

2

GRADO TAGLIO

SALDATURE N°

15°

1

D/	L T	L 1	L 2	L 3	L 4	L 5	L 6	L T	L 1	L 2	L 3	L 4	L 5	L 6	L T	L 1	L 2	L 3	D/
315	1.300	442	400	358	334	250	166	1.050	442	400	358	334	250	166	800	442	400	358	315
280	1.150	388	350	312	300	223	150	925	388	350	312	300	225	150	700	388	350	312	280
250	1.000	323	290	257	277	210	143	790	323	290	257	277	210	143	580	323	290	257	250
225	950	310	280	250	255	195	135	755	310	280	250	255	195	135	560	310	280	250	225
200	900	297	270	243	234	180	126	720	297	270	243	234	180	126	540	297	270	243	200
180	850	284	260	236	213	165	117	685	284	260	236	213	165	117	520	284	260	236	180
160	800	261	240	219	203	160	117	640	261	240	219	203	160	117	480	261	240	219	160
140	700	239	220	201	168	130	92	570	239	220	201	168	130	92	440	239	220	201	140
125	650	227	210	193	160	127	94	535	227	210	193	160	127	94	420	227	210	193	125
110	600	215	200	185	150	120	90	500	215	200	185	150	120	90	400	215	200	185	110
90	500	182	170	158	145	121	97	420	182	170	158	145	121	97	340	182	170	158	90

Misura minima macchina

LAVORAZIONI QUADRE O RETTANGOLARI

da 0 a 250 mm

da 251 mm a 1000 mm

da 1001 mm a 2000 mm

oltre 2001 mm

± mm.

2,5

10

15

20

LAVORAZIONI CIRCOLARI

dal Ø 0 al 50

dal Ø 51 al 250

dal Ø 251 al 500

oltre Ø 501

± mm.

1,5

5

10

15

LAVORAZIONI AD ANGOLO

tutti i Ø

± °

2

90°

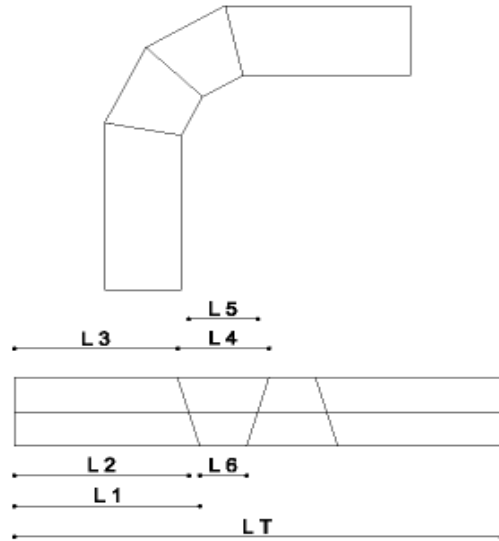

60°

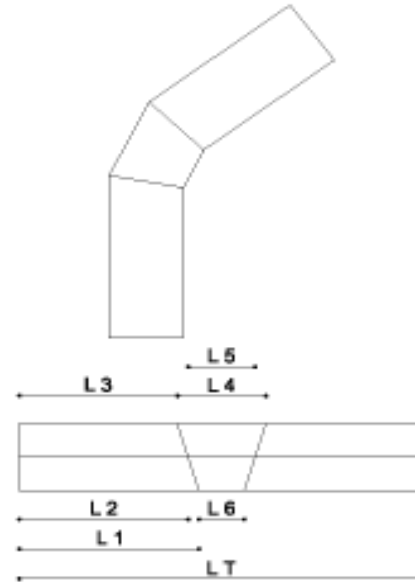

30°

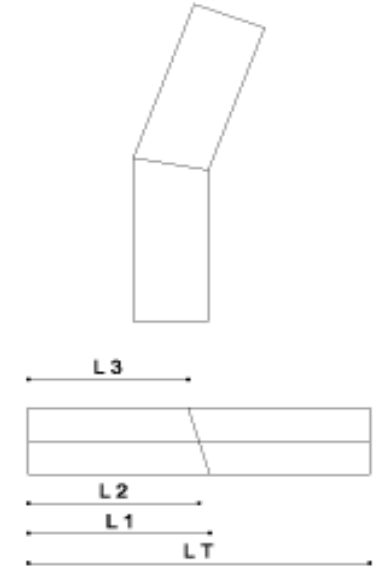

CURVA 90°

CURVA 60°

CURVA 30°

GRADO TAGLIO

15°

GRADO TAGLIO

15°

GRADO TAGLIO

15°

SALDATURE N°

3

SALDATURE N°

2

SALDATURE N°

1

D/	L T	L 1	L 2	L 3	L 4	L 5	L 6	L T	L 1	L 2	L 3	L 4	L 5	L 6	L T	L 1	L 2	L 3	D/
630	2.100	684	600	516	619	450	281	1.650	684	600	516	619	450	281	1.200	684	600	516	630
560	1.900	625	550	475	550	400	250	1.500	625	550	475	550	400	250	1.100	625	550	475	560
500	1.700	567	500	433	484	350	216	1.350	567	500	433	484	350	216	1.000	567	500	433	500
450	1.600	535	475	415	446	325	204	1.275	535	475	415	446	325	204	950	535	475	415	450
400	1.500	504	450	396	407	300	193	1.200	504	450	396	407	300	193	900	504	450	396	400
355	1.400	468	420	372	375	280	185	1.120	468	420	372	375	280	185	840	468	420	372	355
315	1.300	442	400	358	334	250	166	1.050	442	400	358	334	250	166	800	442	400	358	315

Misura minima macchina

LAVORAZIONI QUADRE O RETTANGOLARI

da 0 a 250 mm	± mm.	2,5
da 251 mm a 1000 mm	± mm.	10
da 1001 mm a 2000 mm	± mm.	15
oltre 2001 mm	± mm.	20

LAVORAZIONI CIRCOLARI

dal Ø 0 al 50	± mm.	1,5
dal Ø 51 al 250	± mm.	5
dal Ø 251 al 500	± mm.	10
oltre Ø 501	± mm.	15

LAVORAZIONI AD ANGOLO

tutti i Ø	± °	2
-----------	-----	---

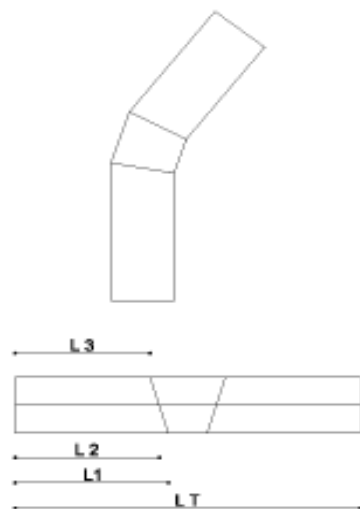
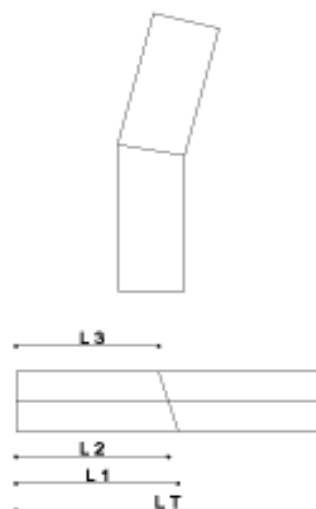
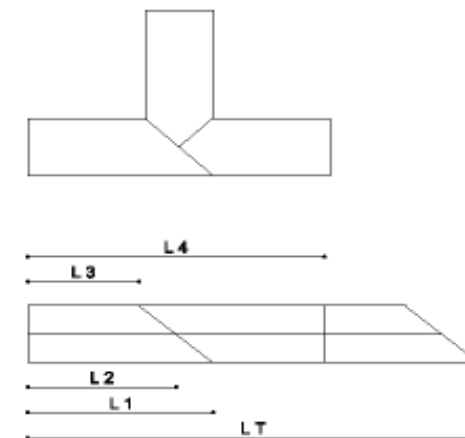
45°

15°

TEE 90°

CURVA 45°				CURVA 15°				TEE 90°							
GRADO TAGLIO				11,25°				GRADO TAGLIO				45°			
SALDATURE N°				2				SALDATURE N°				1			

D/	L T	L 1	L 2	L 3	L 4	L 5	L 6	L T	L 1	L 2	L 3	L T	L 1	L 2	L 3	L 4	D/
315	1.050	431	400	369	313	250	187	800	421	400	379						315
280	925	378	350	322	281	225	169	700	368	350	332						280
250	790	315	290	265	260	210	160	580	306	290	274	1.325	525	400	275	800	250
225	755	302	280	258	240	195	150	560	295	280	265	1.300	508	380	282	790	225
200	720	290	270	250	220	180	140	540	283	270	257	1.150	450	350	250	700	200
180	685	278	260	242	201	165	129	520	272	260	248	1.050	410	320	230	640	180
160	640	256	240	224	192	160	128	480	251	240	229	980	380	300	220	600	160
140	570	234	220	206	158	130	102	440	229	220	211	910	350	280	210	560	140
125	535	222	210	198	140	115	90	420	218	210	202	843	323	260	198	520	125
110	500	211	200	189	122	100	78	400	207	200	193	775	295	240	185	480	110
90	420	179	170	161	98	80	62	340	176	170	164	705	265	220	175	440	90

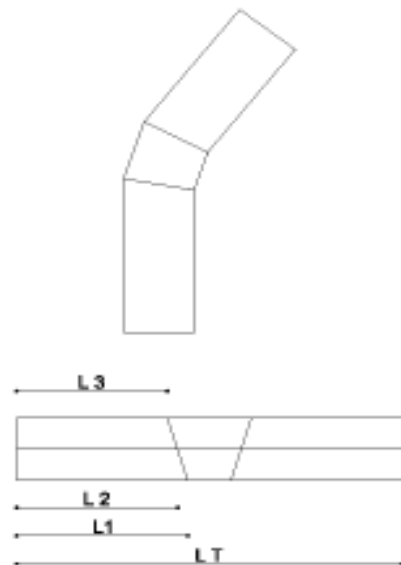
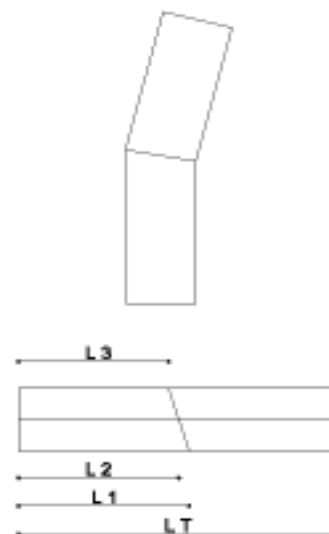
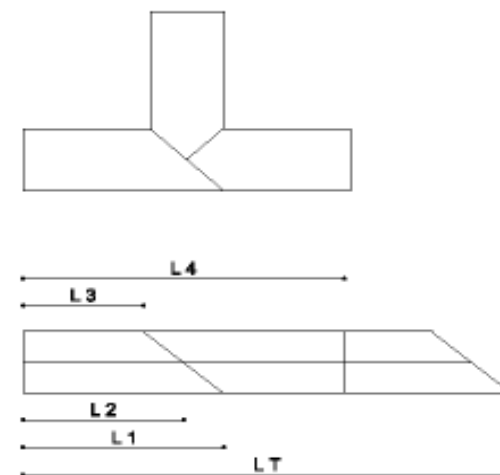
Misura : 1,5 X Ø

LAVORAZIONI QUADRE O RETTANGOLARI			LAVORAZIONI CIRCOLARI		LAVORAZIONI AD ANGOLO	
da 0 a 250 mm	± mm.	2,5	dal Ø 0 al 50	1,5	tutti i Ø	± °
da 251 mm a 1000 mm	± mm.	10	dal Ø 51 al 250	5		
da 1001 mm a 2000 mm	± mm.	15	dal Ø 251 al 500	10		
oltre 2001 mm	± mm.	20	oltre Ø 501	15		

45°

15°

TEE 90°

CURVA 45°				CURVA 15°				TEE 90°															
GRADO TAGLIO				11,25°				GRADO TAGLIO				7,5°				GRADO TAGLIO				45°			
SALDATURE N°				2				SALDATURE N°				1				SALDATURE N°				2			

D/	L T	L 1	L 2	L 3	L 4	L 5	L 6	L T	L 1	L 2	L 3	L T	L 1	L 2	L 3	L 4	D/
630	1.650	663	600	537	575	450	325	1.200	641	600	559						630
560	1.500	606	550	494	511	400	289	1.100	587	550	513						560
500	1.350	550	500	450	450	350	250	1.000	533	500	467	2.340	950	700	440	1.390	500
450	1.275	520	475	430	415	325	235	950	505	475	445	2.175	875	650	425	1.300	450
400	1.200	490	450	410	380	300	220	900	476	450	424	2.000	800	600	400	1.200	400
355	1.120	455	420	385	351	280	209	840	443	420	397	1.830	728	550	372	1.100	355
315	1.050	431	400	369	313	250	187	800	421	400	379	1.660	657	500	343	1.000	315
												1.490	590	450	310	900	218

Misura minima macchina	LAVORAZIONI QUADRE O RETTANGOLARI			LAVORAZIONI CIRCOLARI			LAVORAZIONI AD ANGOLO		
	da 0 a 250 mm	± mm.	2,5	dal Ø 0 al 50	± mm.	1,5	tutti i Ø	± °	2
	da 251 mm a 1000 mm	± mm.	10	dal Ø 51 al 250	± mm.	5			
	da 1001 mm a 2000 mm	± mm.	15	dal Ø 251 al 500	± mm.	10			
	oltre 2001 mm	± mm.	20	oltre Ø 501	± mm.	15			